

**DITHERM  
MTW**

+300°C  
-40°C

**INOX**

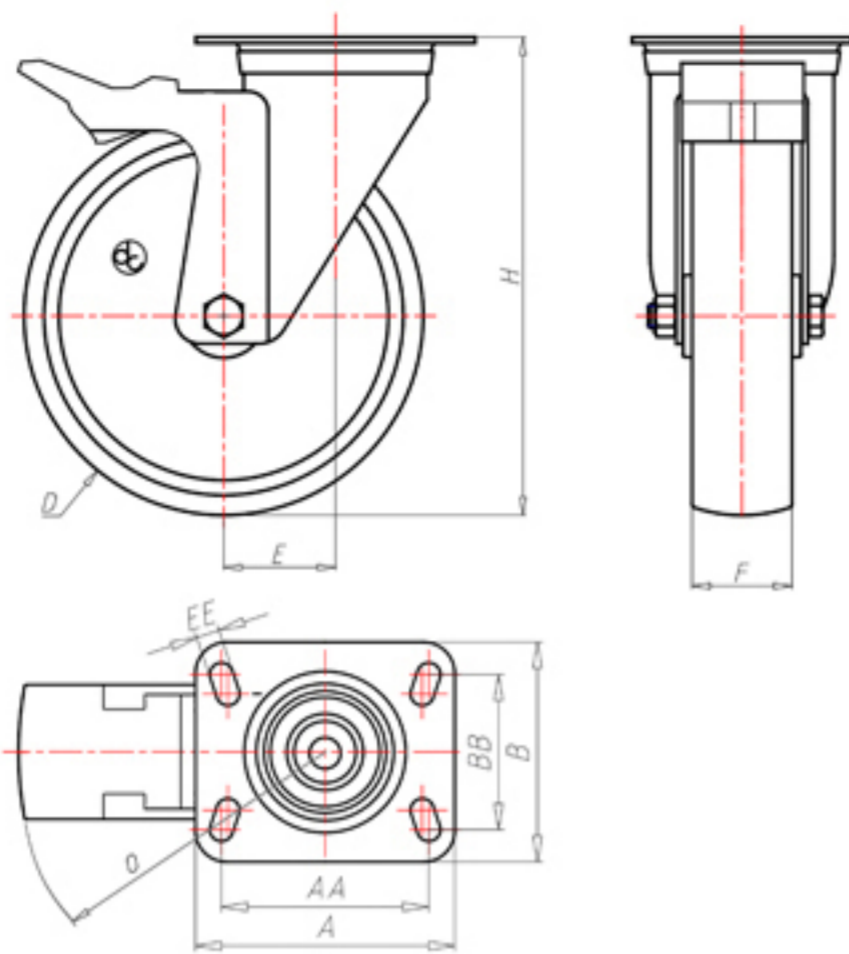

	D	100
	F	35
	H	128
	AxB	100x80
	AAxBB	80x60
	EE	9
	E	42
	O	124
	LC	210



Código para rueda con buje liso

**MGX100FS**



Código para rueda con casquillo revestido en HQS

**MGX100BRFS**



Código para rueda con doble casquillo autolubricante BT

**MGX100BTFS**



Código para rueda con doble rodamiento de bolas HT

**MGX100CFS**



Código para rueda con doble casquillo de bronce sinterizado

-

