

**DITHERM
MTW**

+300°C
-40°C

INOX

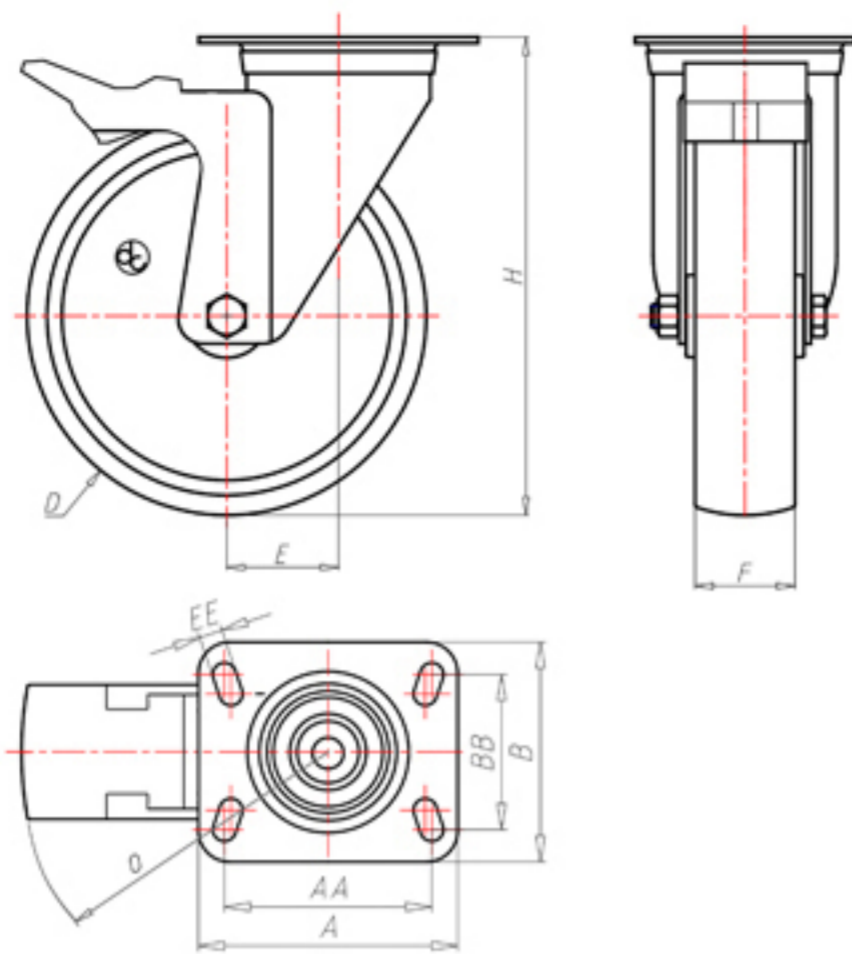

	D	100
	F	35
	H	128
	AxB	100x80
	AAxBB	80x60
	EE	9
	E	42
	O	124
	LC	190



Código para rueda con buje liso

MGX100LFA



Código para rueda con casquillo revestido en HQS

MGX100LBRFA



Código para rueda con doble casquillo autolubricante BT

MGX100LBTFA



Código para rueda con doble rodamiento de bolas HT

-



Código para rueda con doble casquillo de bronce sinterizado

MGX100LBSFA

