

**DITHERM  
MTW**

+300°C  
-40°C

**INOX**

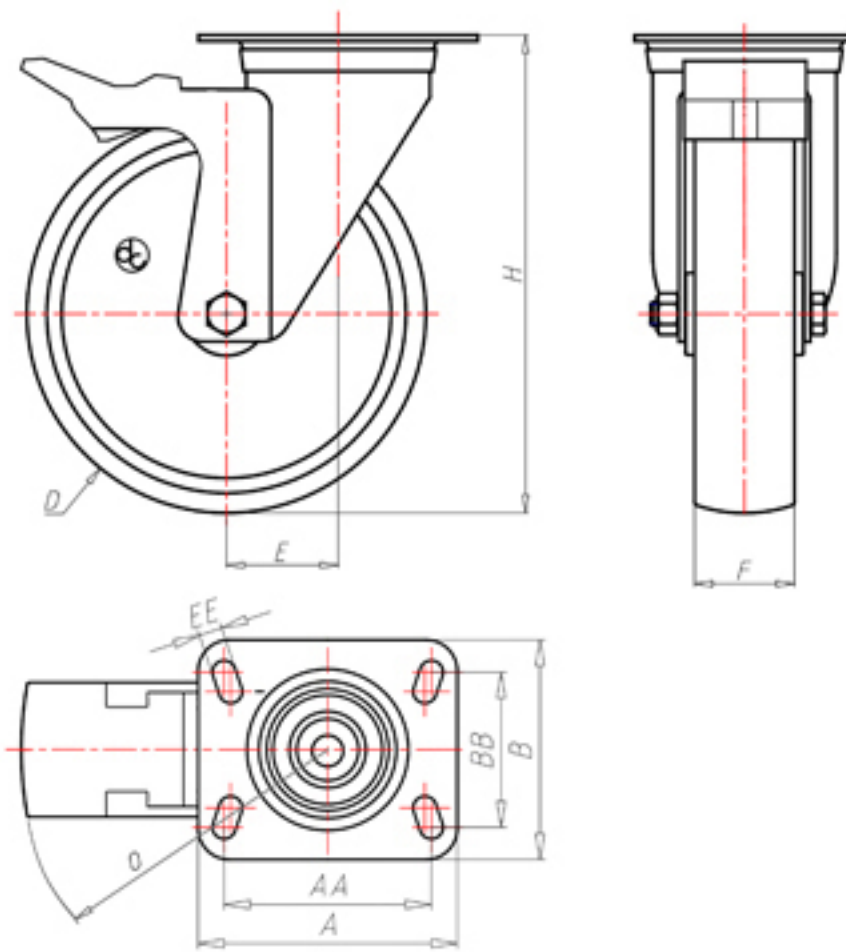

	D	125
	F	40
	H	155
	AxB	100x80
	AAxBB	80x60
	EE	9
	E	44
	O	124
	LC	230



Código para rueda con buje liso

**MGX12545FA**



Código para rueda con casquillo revestido en HQS

**MGX12545BRFA**



Código para rueda con doble casquillo autolubricante BT

**MGX12545BTFA**



Código para rueda con doble rodamiento de bolas HT

-



Código para rueda con doble casquillo de bronce sinterizado

-

