

**DITHERM
MTW**

+300°C
-40°C

INOX

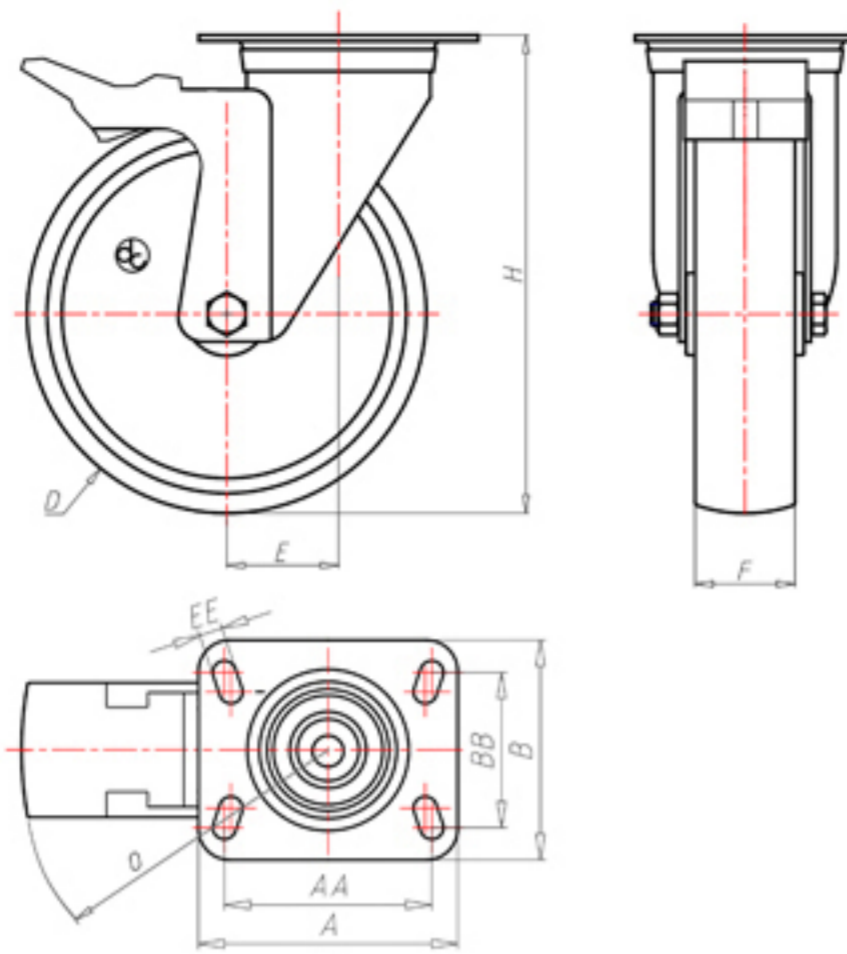

	D	125
	F	40
	H	155
	AxB	100x80
	AAxBB	80x60
	EE	9
	E	44
	O	124
	LC	230



Código para rueda con buje liso

MGX12545FS



Código para rueda con casquillo revestido en HQS

MGX12545BRFS



Código para rueda con doble casquillo autolubricante BT

MGX12545BTFS



Código para rueda con doble rodamiento de bolas HT

-



Código para rueda con doble casquillo de bronce sinterizado

-

