

**DITHERM  
MTW**

+300°C  
-40°C

**INOX**

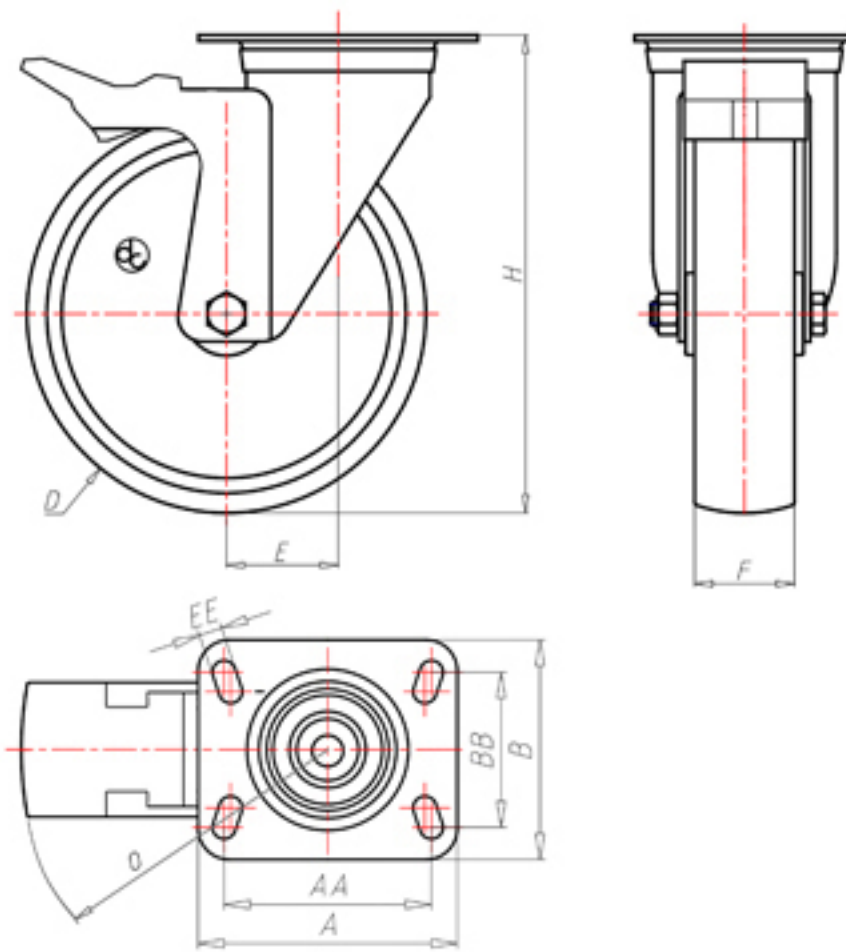

	D	80
	F	35
	H	108
	AxB	100x80
	AAxBB	80x60
	EE	9
	E	40
	O	124
	LC	170



Código para rueda con buje liso

**MGX80FA**



Código para rueda con casquillo revestido en HQS

**MGX80BRFA**



Código para rueda con doble casquillo autolubricante BT

**MGX80BTFA**



Código para rueda con doble rodamiento de bolas HT

**MGX80CFA**



Código para rueda con doble casquillo de bronce sinterizado

**MGX80BSFA**

