

**DITHERM
MTW**

+300°C
-40°C

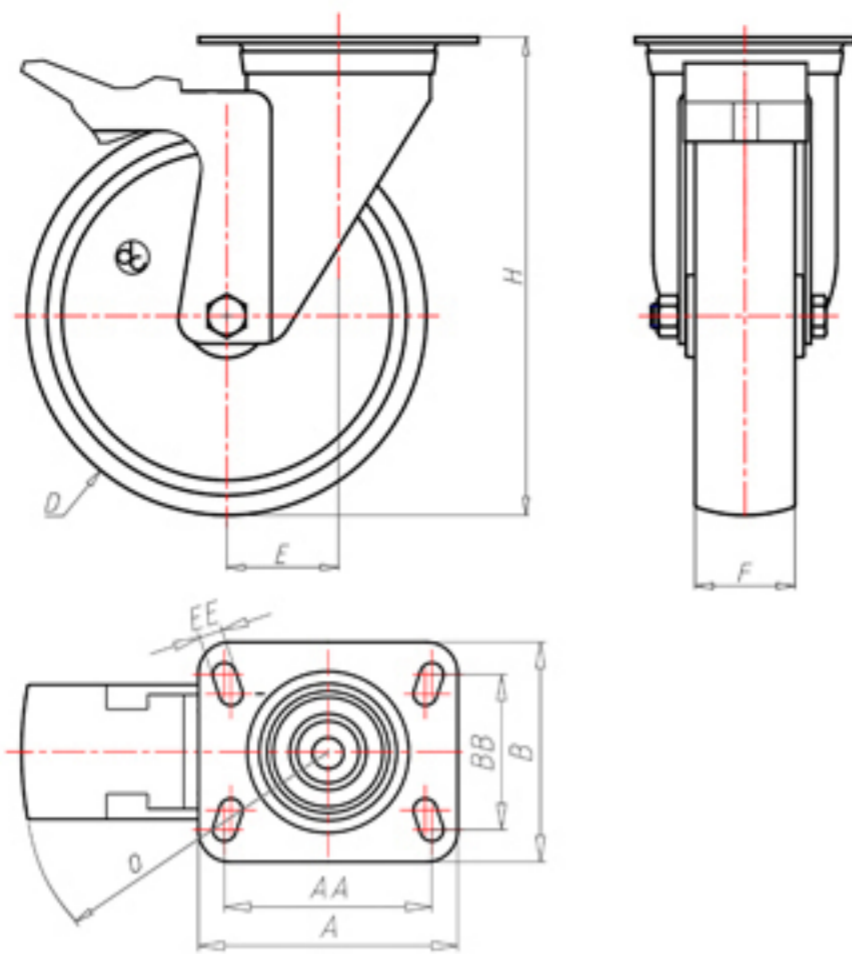

	D	80
	F	35
	H	108
	AxB	100x80
	AAxBB	80x60
	EE	9
	E	40
	O	124
	LC	170



Código para rueda con buje liso

MGZ80FA



Código para rueda con casquillo revestido en HQS

MGZ80BRFA



Código para rueda con doble casquillo autolubricante BT

MGZ80BTFA



Código para rueda con doble rodamiento de bolas HT

MGZ80CFA



Código para rueda con doble casquillo de bronce sinterizado

MGZ80BSFA

