

**DITHERM
STW**

+280°C
-70°C

INOX

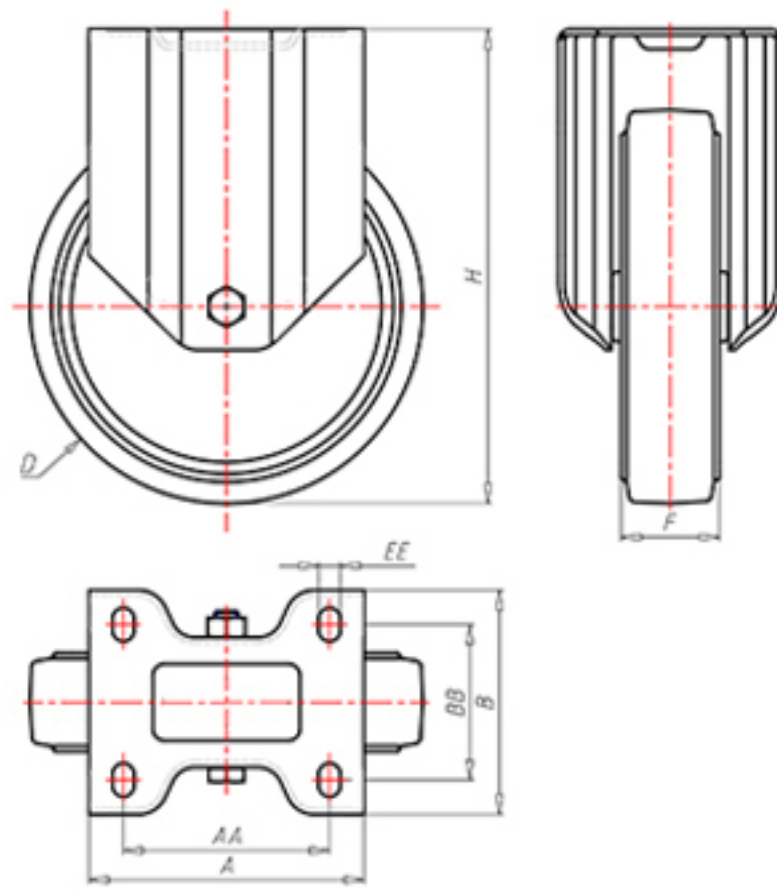

	D	150
	F	40
	H	181
	AxB	135x110
	AAxBB	105x80
	EE	11
	LC	380



Código para rueda con buje liso

SFX15060



Código para rueda con casquillo revestido en HQS

-



Código para rueda con doble casquillo autolubricante BT

-



Código para rueda con doble rodamiento de bolas HT

-

