

**DITHERM
MTW**

+300°C
-40°C

INOX

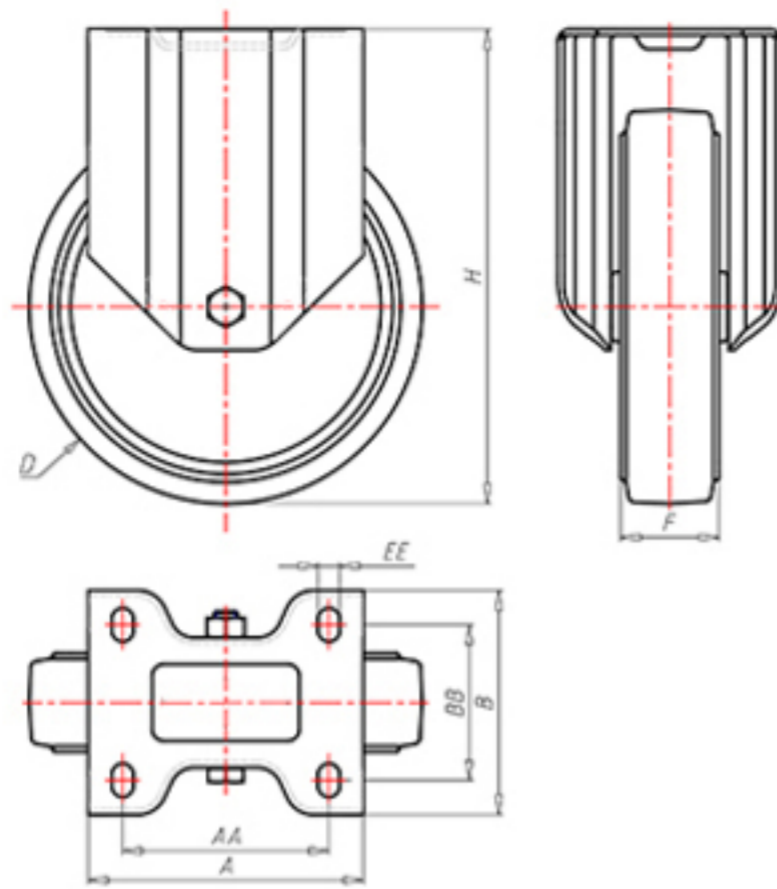

	D	150
	F	45
	H	181
	AxB	135x110
	AAxBB	105x80
	EE	11
	B	
	BB	
	LC	300



Codice per ruota a foro passante

MFX150



Codice per ruota con bussola rivestita in HQS

-



Codice per ruota con doppia boccola autolubrificante in HQS

-



Codice per ruota con doppio cuscinetto a sfere HT

-



Codice per ruota con doppia boccola in bronzo sinterizzato

MFX150BS

