

**DITHERM
MTW**

+300°C
-40°C

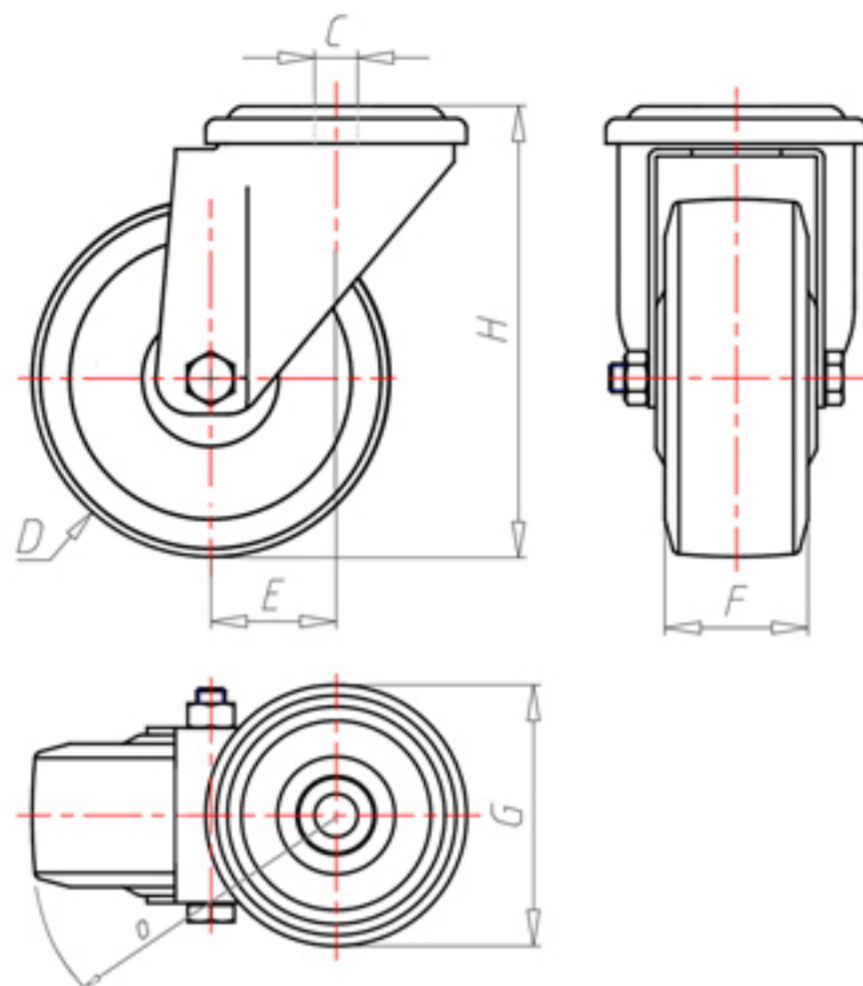

| | | |
|--|----|------|
| | D | 80 |
| | F | 35 |
| | H | 108 |
| | G | Ø 77 |
| | C | Ø 12 |
| | E | 40 |
| | O | 82 |
| | LC | 170 |



Codice per ruota a foro passante

MPZ80



Codice per ruota con bussola rivestita in HQS

MPZ80BR



Codice per ruota con doppia boccola autolubrificante in HQS

MPZ80BT



Codice per ruota con doppio cuscinetto a sfere HT

MPZ80C



Codice per ruota con doppia boccola in bronzo sinterizzato

MPZ80BS

